

MDC100-012101 - 12V, 10A Brushless Controller



FEATURES

- Maximum Current Limit Setting from 1.0-10.0 Amps (Peak)
- Internal or External Potentiometer Speed Control
- 2-Quadrant Operation
- Hall Sensor Feedback
- Short Circuit Protection
- Requires 10 -15 VDC
- Brake, Disable and Direction Inputs
- TTL-CMOS Compatible Inputs
- Compact Size (4.45"x2.66"x1.48")
- Dual Mounting Option
- Detachable, Screw type Terminal Blocks
- CE Certified and RoHS Compliant



DESCRIPTION

The MDC100-012101 driver is designed to drive DC Brushless motors at currents of up to 10A (peak) and 12V. Using hall sensor feedback, a constant velocity mode can be selected. The driver is protected against over current (cycle-by-cycle), hall sensor error and under voltage. When an error occurs, a fault light is turned on to notify the user. Included on the driver is an internal potentiometer to control the maximum phase current allowed into the motor and an internal potentiometer to control the speed of the motor. An optional external potentiometer (10K) or external voltage (0-4VDC) can be used to control the speed as well. The direction of the motor can be preset by the direction control input. Other inputs to the drive include a dynamic brake and a motor disable input. When using the brake input, it overrides all other inputs into the driver.

DIMENSIONS

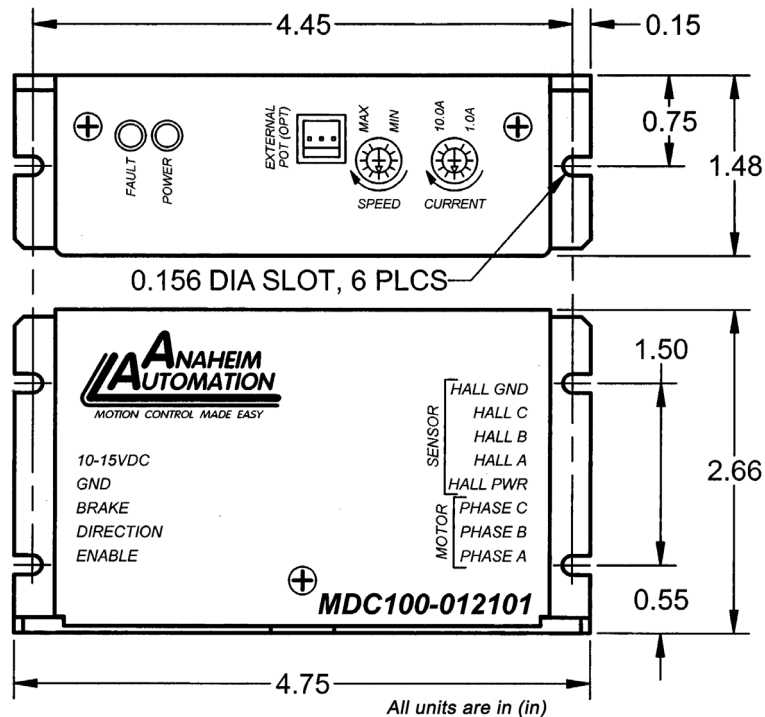

L010594

All units are in (in)

Hookup

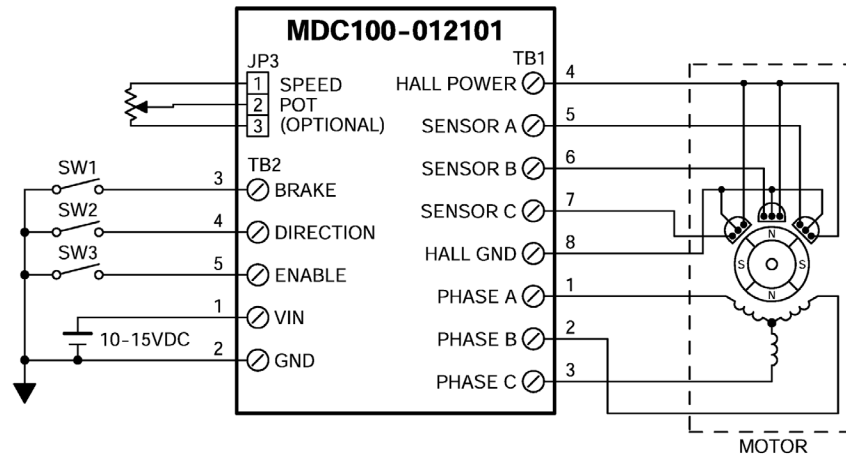

Specifications

Power Requirements:	10-15 VDC
Output Current Range:	1.0-10 Amps (Peak) 0.5 - 5.0 Amps (Continuous)
Control Inputs: (TB1, Pins 1-3)	TTL-CMOS Compatible Logic "1" = OPEN Logic "0" = 0.8 VDC All Three inputs (Run/Stop, Freewheel and Direction) are internally pulled-up through 40 kohm resistors
Freewheel: (TB1, Pin 1)	Logic "1" (Open) - Motor is Enabled Logic "0" - Motor is de-energized and will coast to a stop
Direction Control: (TB1, Pin 2)	Logic "1" (open) - Clockwise Logic "0" - Counterclockwise
Run/Stop: (TB1, Pin 3)	Logic "1" (open) - Motor will not run Logic "0" - Motor will run and will accelerate according to speed setting
Operating Temperature:	0° C to 70°C
Maximum Closed Loop Motor Speed	2 pole: 30,000 RPM 4 pole: 15,000 RPM 6 pole: 11,250 RPM 8 pole: 7,500 RPM
Maximum Open Loop Motor Speed	50,000 RPM

Additional Ordering Information

Model #	Description
MDC100-012101	Featured BLDC driver 10A, 12V
MDC100-050101	BLDC driver 10A, 50V
CBL-AA5420	3 Pin Cable with connector and 12in. Long leads for External Pot